

# Installation & Test Guide

For HP LaserJets & MFPs with 144 Pin DIMM

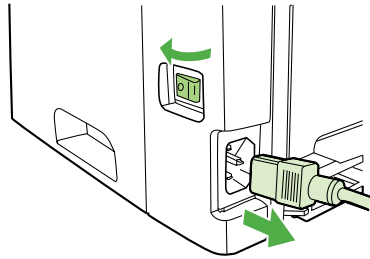

1

Use the power switch to turn off the printer and then unplug the power cord from the printer.

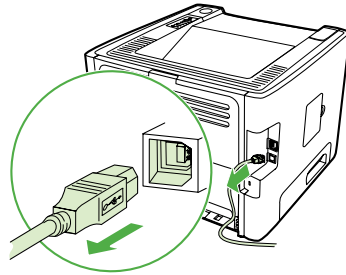

2

Unplug all remaining cables and cords from the printer.

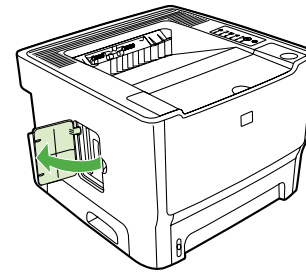

3

Carefully open the DIMM access door located on the left side of the printer.

4

Remove the DIMM from the anti-static bag it came in, grasping the DIMM along the top edge away from the gold contacts.

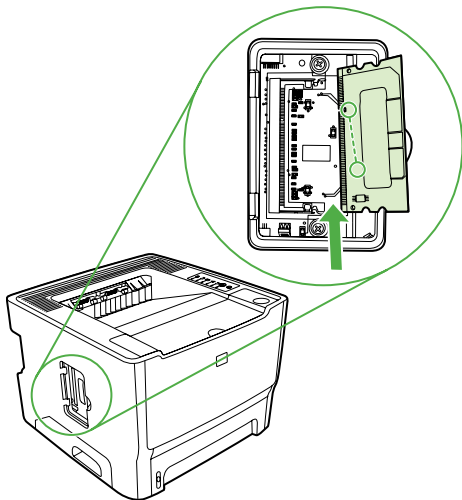
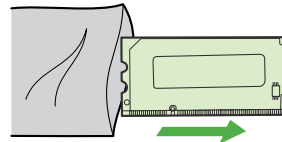

5

The DIMM has a notch cut in the edge between some of the gold contacts. Orient the DIMM so this notch aligns with the bump in the printer's connector and insert the DIMM into the connector.

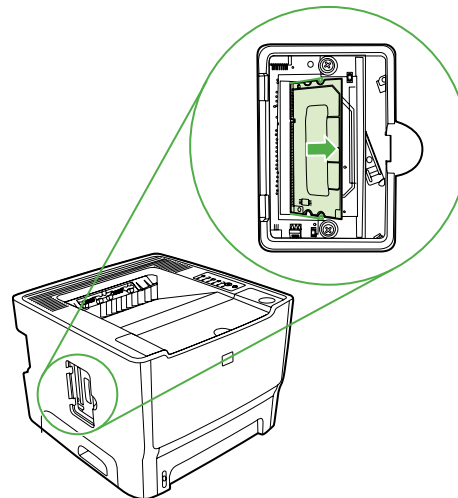

6

Press the DIMM body in until the metal retaining pins click.

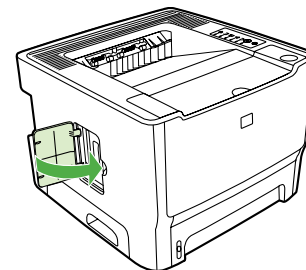

7

Close the DIMM access door, reconnect all cables and cords, then turn the power switch on.

## Congratulations!

You are now ready to print bar codes (and more) using your LaserJet. The CD that came with your BarCodes & More contains an application for testing the new capabilities.

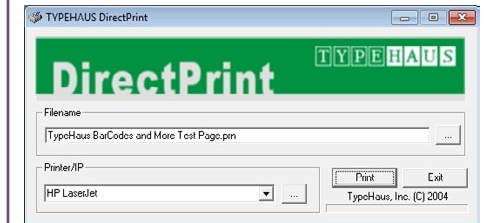

1. Insert the CD in your CD/DVD drive and use Windows File Explorer to browse the CD and double-click on DirectPrint.exe.
2. In the "Filename" section, click the "..." button. Browse to select the file "TypeHaus BarCodes and More Test Page.prn" also located on the CD.
3. In the "Printer/IP" section, select the printer from the dropdown list or enter the IP address if it is attached to the network.
4. Select the "Print" button.
5. Compare the printed test page to the reverse side of these instructions.
6. Select the "Exit" button to close the application.

TypeHaus Reorder Part Number: 11B583-20

Solutions  
Business Partner



TypeHaus, Inc.  
655 Second Street  
Encinitas, CA 92024  
760.334.3555  
www.typehaus.com

**BarCodes & More**

**Test Page**



Extending the Resources and Abilities of Your Printer

**BarCode 39**

4.69 CPI / 12 Point  $E_c(0Y^{E_c}(s0p4.69h12v0s0b0T$

8.11 CPI / 12 Point  $E_c(0Y^{E_c}(s0p8.11h12v0s0b0T$

**BarCode 128**

4.36 CPI / 12 Point  $E_c(2Y^{E_c}(s0p4.36h12v0s0b0T$

8.33 CPI / 12 Point  $E_c(2Y^{E_c}(s0p8.33h12v0s0b0T$

**UPC BarCode**

10 mil / 12 Point  $E_c(8Y^{E_c}(s1p12v0s0b0T$

13 mil / 12 Point  $E_c(8Y^{E_c}(s1p12v0s3b0T$

**USPS Zip**  
 12 Point  $E_c(15Y^{E_c}(s1p12v0s0b0T$

**Line Draw**

10 CPI / 12 Point  $E_c(0B^{E_c}(s0p10h12v0s0b0T$

**Letter Gothic**

16.67 CPI / 9.5 Point  $E_c(8U^{E_c}(s0p16.67h9.5v0s0b6T$  ABCDEFgHabcdef012

12 CPI / 12 Point  $E_c(8U^{E_c}(s0p12h12v0s0b6T$  ABCDEFgHabcdef012

10 CPI / 14 Point  $E_c(8U^{E_c}(s0p10h14v0s0b6T$  ABCDEFgHabcdef012

**OCR-A**

10 CPI / 12 Point  $E_c(0O^{E_c}(s0p10h12v0s0b104T$  ABCDEFgHabcde f012

**OCR-B**

10 CPI / 12 Point  $E_c(1O^{E_c}(s0p10h12v0s0b110T$  ABCDEFgHabcde f012